



Contents

2 Introduction

2 Welcome

3 Overview

4 Setting up

4 Remove the cover

4 Install your SIM card

5 Connect the battery

5 Replace the cover

5 Position the terminal

6 Connect the antenna, telephone and power adapter

7 Switch on

8 Data and fax connections

9 Configuring and connecting the terminal for data

14 Everyday use

14 Status indications

15 Making and receiving calls

15 Ring back test

15 Power loss during operation

16 Security: PIN and PUK codes

16 Call waiting

17 In-call dialling

17 Conference calls

18 Configuration codes

19 Basic configuration codes

24 Advanced configuration codes

24 Call forwarding

25 Call barring

26 Call waiting

27 Security features

27 Phone number presentation

28 Further information

28 Troubleshooting

28 Important safety information

30 Index

Introduction

Welcome

Thank you for choosing the Burnside T350 or T390 *fixed cellular terminals* - these devices allow you to use a standard telephone in locations where landline phone connections are unavailable, impractical or too expensive. The T390 variant provides exactly the same facilities as the T350 unit, but with the addition of GPRS (General Packet Radio Service) for increased data communication rates.

Your Burnside T350/T390 terminal allows any attached telephone to be used in the same way as a normal telephone.

Supplied items

In addition to this guide, please ensure that you have the following:

- Burnside T350 or T390 terminal,
- Compact antenna,
- Mains power adapter,
- Telephone cable adapter (not supplied in all kits),
- USB connections cable (not supplied in all kits).

Additional items that you will require

- A valid SIM card,
- A touch tone telephone (preferably one that includes a caller identification feature on its display: *Calling Line Identification [CLI] or Caller ID*). You can also use a cordless phone base station, but not an ISDN phone, VoIP phone or non-standard phone designed for use with a PBX.

Overview

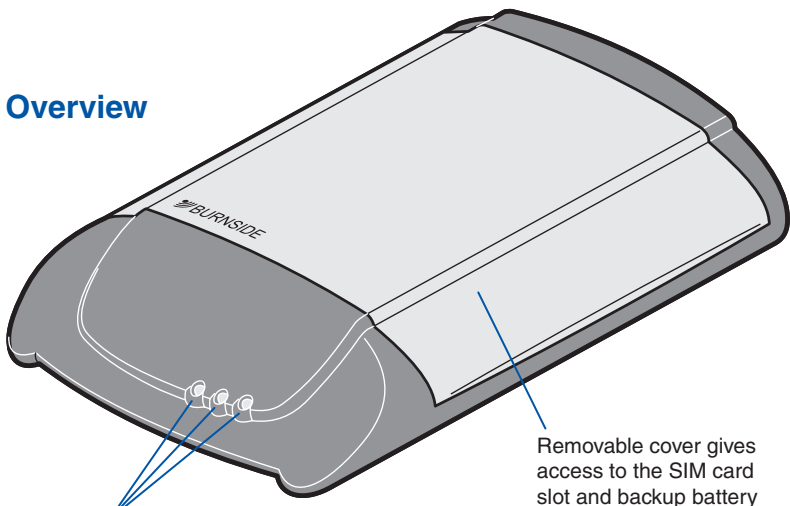

Indicators

Provide status information about power input and other operational factors

Removable cover gives access to the SIM card slot and backup battery

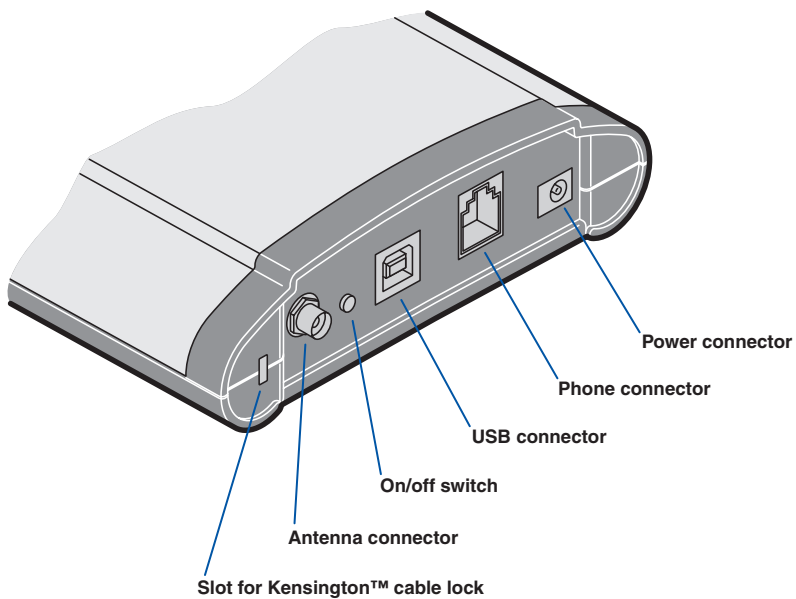

Setting up

Remove the cover

- 1 Place the terminal on a level surface.
- 2 Grip the ridges on either side of the light-grey top cover and lift it gently from the base unit. This will reveal the SIM card holder and the battery.

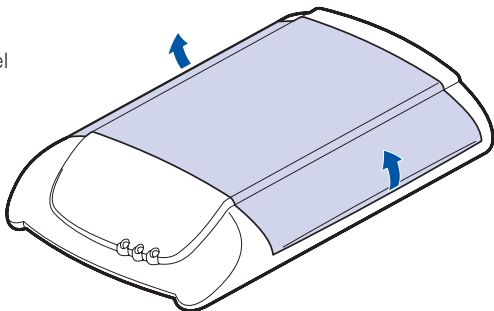

Install your SIM card

Note: Ensure the T350/T390 is switched off before installing a SIM card (the front panel indicators should not be illuminated or flashing).

If they are, remove the power connector and, if necessary, press and hold the small red button on the rear panel until the amber and centre green indicators illuminate, and then release the button.

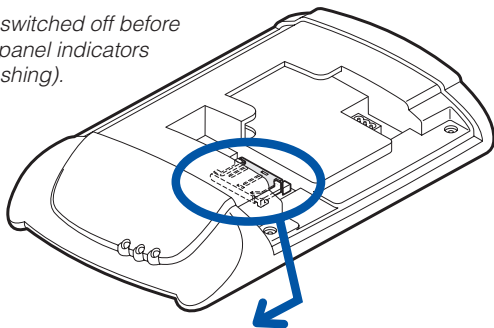

- 1** (a) Slide back the hinged lid to unlock it, then (b) swing it open.

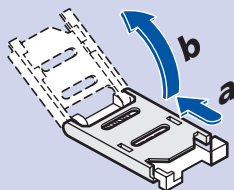

- 2** (a) Insert the SIM card into the hinged lid as shown.

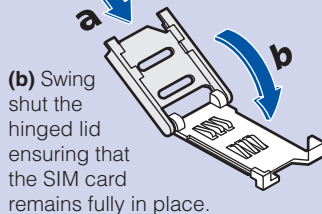

- 3** Press down on the hinged lid and slide it forward so that it locks into place.

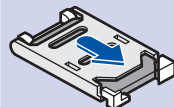

Connect the battery

Your terminal may have been shipped with its battery disconnected. If so:

- 1 Locate the battery lead and plug it gently but firmly into the adjacent socket (it will fit one way only, however, take extra care to fit it correctly with the black wire closest to the rear corner of the unit).

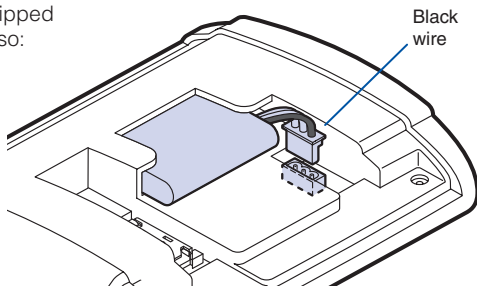

Replace the cover

- 1 Align the cover correctly with the base unit.
- 2 Press the cover onto the base until it clicks into place. If the unit is to be wall mounted, you can reverse the cover so that the lettering is the correct way up.

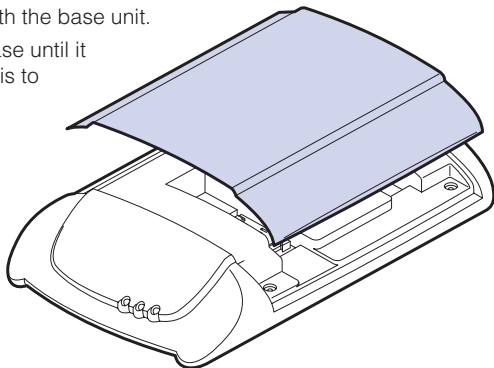

Position the terminal

Before connecting the external items to your terminal, place the unit in a suitable location, but keep it at least one metre from your telephone to avoid interference. See the inside rear page for a wall mounting template.

Low signal strength

If the signal strength is insufficient (indicated by the amber and centre green indicators both flashing once every two seconds), you may need to adjust the position of the antenna.

Connect the antenna

- 1 Align the supplied antenna (or another suitable GSM antenna) with the circular connector on the far left of the rear panel.
- 2 Attach the antenna and twist the connector collar clockwise until it is finger-tight - do not overtighten.

Note: In use, the antenna should always be vertical. The supplied antenna has a hinge so that you can position it correctly. When the unit is wall mounted the antenna should point straight down. See the inside rear page for a wall mounting template.

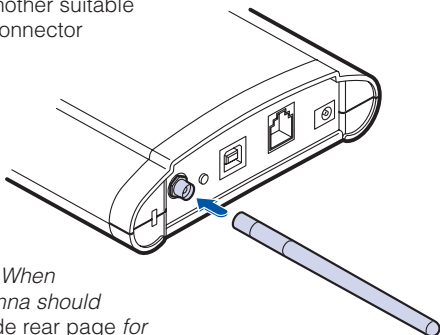

Connect a telephone

- 1 Connect a standard corded telephone to the socket on the rear panel. If your phone has a different connector than a standard RJ11 type, use an adaptor (supplied in some kits).

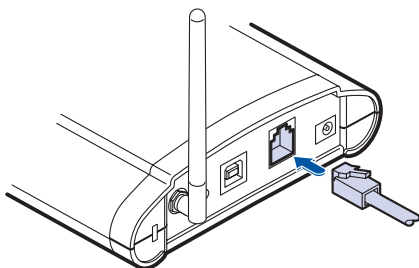

Connect the power adapter

- 1 Attach the connector from the power adapter to the socket on the far right of the rear panel.
- 2 Plug the power adapter into a nearby mains outlet.

The right hand green indicator on the front panel should illuminate to show that power is supplied.

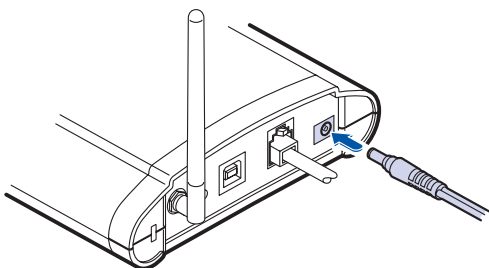

Switch on

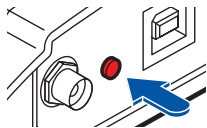

On the terminal rear panel, press and hold the red button until the front panel amber and centre green indicators illuminate, then release the button. *Note: If the indicators fail to illuminate when the button is pressed, the battery may be fully discharged. If so, please allow up to one hour for the battery to obtain sufficient charge.*

The centre green indicator will show a rapid on/off flash while the terminal initialises itself (approx 15 secs).

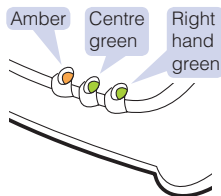

When the initialisation is complete, the terminal will do one of two things (depending on whether a PIN code is required):

Centre green indicator extinguishes and amber indicator shows a rapid on/off flash.

This indicates that a PIN code is required to unlock the SIM card.

Centre green indicator changes to a short flash every two seconds.

This is the 'standby' flash and shows that the terminal is ready for use. Please see page 14 for further details.

Enter a PIN code

- 1 Lift the handset (you will hear a series of short tones instead of a dial tone).
- 2 On the telephone keypad, dial the following:

***8* [PIN code] #** where [PIN code] is a 4 to 8-digit code for the SIM card.

- If the code is accepted: You will hear two short beeps, the amber indicator will extinguish and the centre green indicator will show a short 'standby' flash every two seconds. The terminal is now ready for use, please see the next page for details about making and receiving calls.
- If the code is rejected: You will hear a single low pitched beep. Check that you have the correct PIN code for the SIM card in use, replace the handset and then try again. *Note: If you enter an incorrect PIN code three times, the SIM card will lock and you will need to get a special unblocking (PUK) code (see page 16 for details).*

Switching off

On the terminal rear panel, press and hold the red button until the front panel amber and centre green indicators illuminate, then release the button. These two indicators should then switch off and remain off. The right hand green indicator will remain on until the power input is removed.

Data and fax connections

The T350 and T390 terminals both support low speed CSD (Circuit Switched Data) data communication and digital fax over the GSM network. Standard CSD data rates are either 9600bps or 14400 bps depending on the GSM service.

Note: During a voice call, an incoming CSD call or fax will experience the number as busy. If an attempt is made to make an outgoing CSD or fax call from the connected computer, the voice call will be disrupted. When an outgoing voice call is attempted, the terminal will report the busy tone.

The T390 model additionally supports GPRS (General Packet Radio Service) data communication which can operate at up to 86 kbps, suitable for email and light-duty web surfing. In addition, GPRS can be used as an “uplink” data connection for a satellite-based broadband service.

Note: GPRS connections can remain active at all times, if required. When data is flowing, new incoming and outgoing voice calls will be met with a busy tone. When a voice call is established, an attempt to send/receive data will result in a failure, for example a “server not found” message. When the voice call has ended, the data connection may resume without any special intervention.

TAPI compatibility

Some applications, such as contact management or phone diallers, may require TAPI compatible voice dialling commands.

To initiate TAPI mode, dial ***8821#**. To revert to the GSM voice dialling command protocol, dial ***8820#**.

Configuring and connecting the terminal for data

Notes:

It is important to install the Windows driver **before** connecting the terminal to the computer.

A USB type B interface is provided for connection to a computer using a standard USB type A to B cable (supplied in some kits).

These instructions cover installation on Windows XP, however, drivers are also included for Windows 98SE, Windows Me and Windows 2000.

Stage 1 - Install the drivers

- 1 Insert the installation CD-ROM (if supplied) or download and save the necessary USB driver file from the Burnside Telecom website (<http://www.burnside-telecom.com/site.php/00002.html>). For the downloaded file, you will need to use the utility PKZIP® (www.pkware.com) to decompress and save the files held within.
- 2 From the CD-ROM or the downloaded files, locate and run the file: **CP210xVCPInstaller.exe**. It may be necessary to temporarily turn off any virus protection. The driver will install two *layers*; a 'USB layer' and a 'COM port layer'. When prompted, accept the installation.
- 3 Connect one end of a USB type A to B cable (supplied in some kits) to the USB socket on the rear panel of the terminal.
- 4 Connect the other end of the cable to a vacant (type A) USB socket on the computer system.
- 5 To establish which COM port has been assigned, this can be viewed from the control panel/system properties/hardware/device manager as shown below:

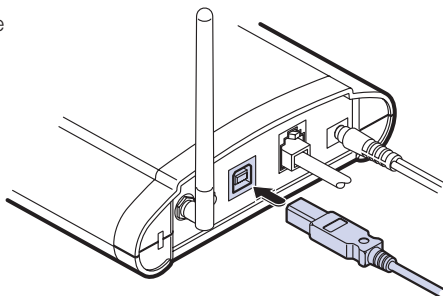

Note: To remove the driver, use the Add/Remove programs function from the system control panel and select "CP210xUSB to UART Bridge Controller"

Stage 2 - Configure Windows

To use most applications on Windows such as an email client, web browser or dialler, it is necessary to set up a standard modem.

To set up a connection in Windows XP:

- 1 In the Control Panel, select 'Phone & Modem Options', select the 'Modems' tab and then click the 'Add...' button.
- 2 In the 'Add Hardware Wizard' window, select the 'Don't detect my modem...' option and click the 'Next >' button.
- 3 Under "Manufacturer" select 'Standard Modem Types', under 'Models' select 'Standard 19200 bps Modem' and click the 'Next >' button. A list of available ports will be displayed.
- 4 Select the port that is assigned to the T350/T390 terminal, such as COM4 (see step 5 on the previous page for details about how to find out) and click the 'Next >' button.
- 5 When prompted, click the 'Finish' button. Now the modem is installed, select 'Properties' and then select the 'Maximum Port Speed' to be '115200'. This is the basic configuration for all models.

To connect to the internet using this modem connection, create a new dialup networking configuration in the normal way, suitable for your ISP and make sure the "connect using" is set to the "standard 19200 modem"

You are now ready to connect.

Fax

You can use the terminal to send and receive faxes from a PC using fax software. We recommend the fax capability that is installed as standard in Windows XP Professional (free option provided with Windows XP Home). You can send a fax with most SIMs and services including "pay as you go" but before you can receive a fax, you will need to obtain a dedicated fax number from your service provider and this is normally only available with a contract SIM.

GPRS

To make a GPRS connection, you must configure the terminal by assigning an initialisation command in the modem Advanced section of the modem Properties:

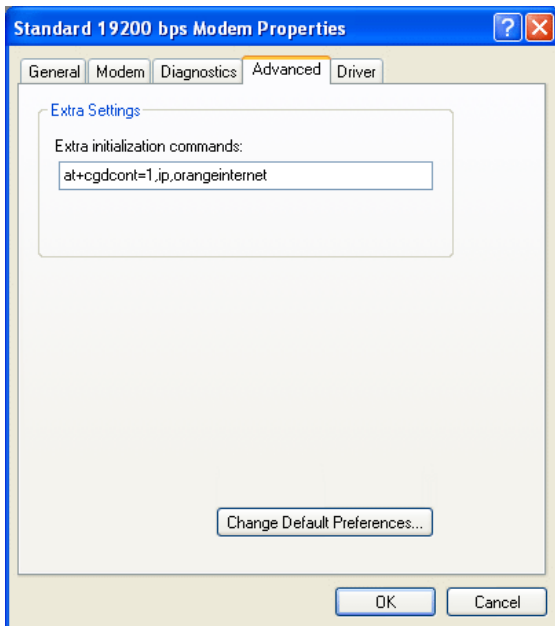

The string should be `<at+cgdcont=1,ip,orangeinternet>` where 'orangeinternet' is the Access Point Name (APN), see below for more examples:

UK GPRS settings

Mobile Operator	APN	Username	Password
Vodafone	internet	web	web
O2	mobile.o2.co.uk	mobileweb	password
T Mobile	general.t-mobile.uk	user	wap
Orange	orangeinternet	user	pass
Tesco-mobile	prepay.tesco-mobile.com	tescowap	password
BT Mobile	btmobile.bt.com	user	wap
Virgin	goto.virginmobile.uk	user	(leave blank)

Please consult with your service provider if the above settings do not work, they may have changed.

continued

Now assign the phone number for GPRS which is *99***1# (star 99 star star star 1 hash) see below:

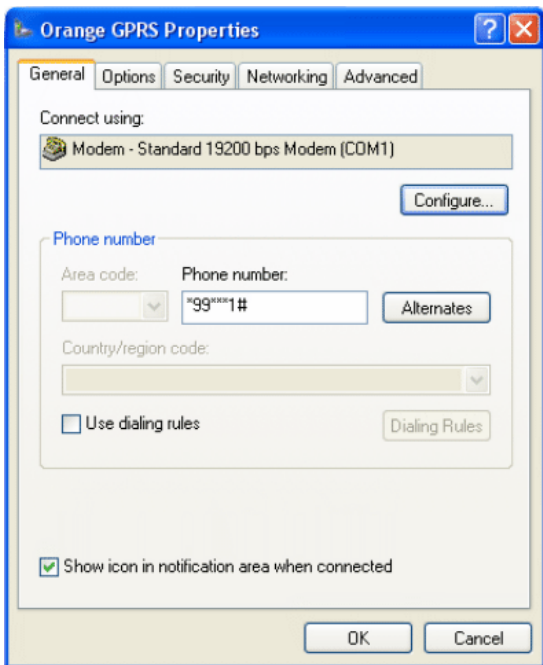

Testing the driver installation

After the device driver has been installed and a COM port assigned, make a test connection using Hyperterm (accessories/communications). The connection will be direct to COMx and select 115200 8/N/1.

Enter AT<cr> and you should see the OK response. Enter ATI<cr> and the model number of the Siemens GSM module will be displayed.

SMS server

The terminal is particularly suitable for SMS server applications that fully utilise ETSI compliant commands for sending and receiving SMS. This can also co-exist with voice applications such as LCR on a PBX.

SMS sender

There is a free "SMS Sender" application from Microsoft. This will work with the terminal. To locate the application, search for "Microsoft SMS Sender".

Everyday use

The terminal aims to make the operation of the attached phone very straightforward and as close as possible to using a standard landline phone. There are numerous operational factors involved in achieving normal operation and the terminal uses its front panel indicators (and also plays tones through the phone earpiece) to communicate its current status.

Status indications

Standby

When the terminal is ready to make and receive calls it will show the following (standby) indications ➔

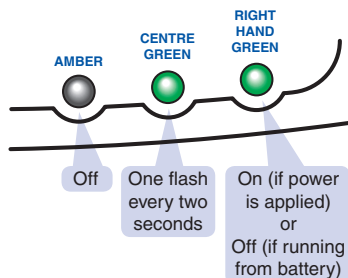

Other indications

The amber and centre green indicators provide status information by flashing on and off in various ways as shown below.

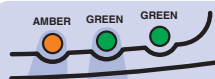

Initialising/searching



Standby - ready for use



Incoming call



Call in progress



SIM card is locked, valid PIN code required (page 16)



SIM card is blocked, PUK code required (page 16)



Weak signal



Battery low, please wait



Fault

In these representations, each complete circle represents two seconds and the shaded portions show the period for which each indicator is on within that two seconds.

Switching on and off

Please see page 7 for details.

Making calls

Use the attached phone almost exactly as you would use a standard landline phone.

- 1 Lift the handset and listen for a dial tone.

If you hear a series of short tones, the terminal is either waiting for a PIN code (see page 7) or no SIM card is installed.

- 2 Dial the required number and then press the # key to place the call.

If you do not dial #, the call will be placed automatically, three seconds after the last button is pressed. You can adjust the delay period (see page 19).

Emergency calls

If the SIM is locked or there is not even a SIM installed, it will still be possible to make emergency calls provided there is sufficient signal coverage. Simply dial the **112** international emergency number or the country specific emergency number defined by your SIM (e.g. **999** in the UK).

Receiving calls

When the phone rings, lift the handset and take the call in the normal way.

If the caller's number is made available by the network, and the attached phone supports Caller ID, it will be shown on the display of the phone.

Ring back test

The ring back test can confirm the link with the attached phone as well as the Caller ID feature (if supported) and the current ring style. If possible, you should also test by making calls to, and receiving calls from another phone.

- 1 Lift the handset and dial ***9#**

- 2 Replace the handset. The attached phone should ring (for 30 seconds or until you lift the handset).

If the attached phone supports Caller ID, the display should show the number '01234567890' and the message 'Test Call'.

Power loss during operation

If the terminal loses mains power during normal operation, it will revert to using its internal battery. Once the battery level becomes low, the terminal will automatically switch off. If power is restored, the terminal will automatically resume operation without requiring the power button to be pressed. Battery charging is controlled automatically.

Security: PIN and PUK codes

If the SIM card is locked, instead of a dial tone you will hear short beeps indicating that a valid PIN code is required. Enter the PIN code using the sequence:

***8* [PIN code] #**

If you make a mistake before pressing the # key, hang up and start again.

Take care to correctly enter the PIN code. The SIM PIN mechanism is designed to provide a high level of protection. Only three consecutive attempts are permitted for normal PIN code entry, after which an unblocking code (PUK) will be required. This is protected by several levels of time prevention to avoid repeated guessed attempts. A total of ten attempts are allowed before the SIM becomes unusable. See page 21 for further details about entering PUK codes.

Time to wait before next PUK input is allowed:

1st failed attempt No time to wait

2nd failed attempt 4 seconds

3rd failed attempt 3 * 256 seconds

4th failed attempt 4 * 256 seconds

5th failed attempt 5 * 256 seconds

6th failed attempt and so forth 6 * 256 seconds, etc.

The standard PIN code can be between 4 and 8 digits. The PUK is always 8 digits and can be obtained from your service provider.

Special call features

The terminal supports special network call features that give you greater flexibility. Special call features require the use of the button on the attached phone which is commonly labelled **RECALL** or **R**.

Call waiting

Providing call waiting is enabled (see the 'Advanced configuration codes' section) and supported by your network, an incoming call whilst the phone is in use will sound a tone in the handset. You have the following options:

Call waiting options

- To ignore the call, wait until the caller either hangs up or is diverted.
- To reject the waiting call and continue with the active call, press **R0**.
- To end the active call and accept the waiting call, press **R1**.
- To put the active call on hold and accept the waiting call, press **R2**.
- To swap between the held call and the active call, press **R2** again.

In-call dialling

To make another call while one call is already active.

- Press the **R** key and dial the number. The active call will be put on hold.
- To swap between the held call and the active call press **R2**.

Conference calls

To have a conversation with two or more parties.

- Dial the first person in the normal way.
- Press **R** and then dial the next person.
- Press **R3** to create a conference call.
- To add another person, press **R** and dial the next number. When the person answers, press **R3** to join them to the conference.

If the call is answered by voice mail or the wrong person, press **R1** to reject and return to the conference.

To end the conference call, hang up the telephone.

- To remove one person from the conference, press **R1x** (*where x is the number of the person in the order the call was set up*).
- To have a private conversation with one member of the conference, press **R2x** (*where x is the number of the person in the order the call was set up*). The other parties will be placed on hold. To return to the conference, press **R3**.
- To transfer the call to the other parties and end your call, press **R4**.

Notes:

- *The availability of these facilities are dependant on the SIM card and service provider.*
- *If you try to add a party to a conference call and the call is answered by the voice mail, you should disconnect that party otherwise the conference may be recorded to voice mail until it becomes full.*
- *Replacing the handset phone will terminate all calls (held, calling, active or waiting).*
- *If there is an incoming call while the phone is in use but no call is active, a ringing tone will be heard through the handset. When the handset is replaced, the phone will ring and the call may be answered in the normal way.*

Configuration codes

The terminal offers many configuration options which are all selected by using the attached phone to enter the configuration codes that are detailed within this section.

Entering configuration codes

- 1 When not in a call, lift the phone handset.
- 2 Carefully dial the required code sequence, as listed in this section.

The attached phone will audibly respond to the entered codes in one of two ways:

- **Two short mid tones** - the code has been accepted.
- **One long low tone** - the code has been rejected.

Conventions

In this guide, configuration code items in **[square brackets]** are mandatory, whereas items in **<chevron brackets>** are optional.

Basic configuration codes

The codes within this sub-section are concerned with the general set up and behaviour of the terminal and the attached phone.

Basic configuration code format

The basic configuration codes all adhere to the following basic format:

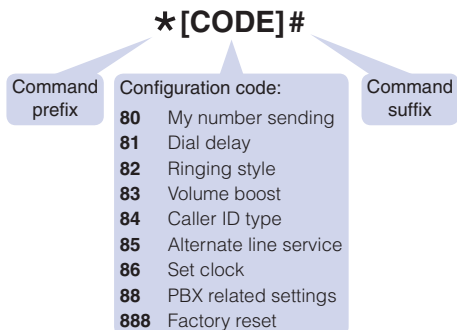

My number sending [80]

This determines whether your telephone number should be declared to the person being called.

- Use the standard network config for Caller ID (CLI) sending (default) ***801#**
- Always send Caller ID (CLI) information, irrespective of the standard network configuration. ***802#**
- Always withhold Caller ID (CLI) information, irrespective of the standard network configuration. ***803#**

Note: You can override the above settings and send/withhold your number by using the following prefix codes:

***31#[phone number]** to make a call and declare your number, or
#31#[phone number] to make a call and withhold your number.

Dial delay [81]

This determines the delay following the last digit pressed, to placing a call using the number that has been entered. The standard setting is 3 seconds. The range is adjustable between 1 and 9 seconds, in one second intervals.

***81[delay]#** where [delay] is a value between 1 and 9.

For example, to set a four second delay, enter: ***814#**

Note: Regardless of the delay setting, a call can be started immediately by entering # at the end of the number.

Ringling style [82]

This determines which of five ringling styles (cadences) that the attached phone should use to announce incoming calls. The standard setting is 1, the standard UK ringling style.

- UK style ***821#**
- German style ***822#**
- French style ***823#**
- Spanish style ***824#**
- US style ***825#**

*Note: Use the ring back test (*9#) to hear the chosen ringling style.*

Volume boost [83]

This allows you to apply a boost to the earpiece audio level, for use in noisy environments. The standard setting is 0 - no boost.

***83[boost]#** where [boost] is a value between 0 and 3.

Caller ID type [84]

This determines which Caller Line Identity (CLI) or Caller ID type will be used to communicate to the attached phone. CLI is a convenient and useful feature that allows the phone to display a caller's telephone number, date, time and name (if there is a match in the phonebook) before the call is answered.

- No CLI ***840#**
- ETSI V23 (default) ***841#**
- Bellcore (USA) ***842#**
- ETSI DTMF ***843#**
(legacy European system)

Alternate line service [85]

If your SIM card supports two numbers for voice calls, you can select which line to use for outgoing calls.

- Select line one ***851#**
- Select line two ***852#**

Set clock [86]

The terminal uses an internal clock to provide revised date and time information to the attached phone (via the Caller ID function) every time an incoming call is received.

The date and time information will be maintained providing the battery is connected and has some power remaining, even if the terminal is switched off. However, if the battery is disconnected, the date and time will be lost.

***86*[YYMMDDHHMMSS]#**

For example, to set 10:25:30 on 14 February 2007,

enter: ***86*070214102530#**

*Note: You can optionally use the ring back test (***9#**) to immediately send the entered date and time to the phone.*

PBX related settings [88]

End of call signalling

This determines the method used to indicate that an incoming call has ended. No change is usually required, however, this may require alteration if the terminal is connected to certain PBX equipment.

- Progress tone and K-Break (default) ***8801#**
- Progress tone and line reversal ***8802#**
- Progress tone ***8803#**

Recall/flash-hook control

This controls the recall/flash hook functions and can be altered to avoid inadvertently activating in-call functions when the terminal is connected to a PBX.

- Disable recall/flash hook functions ***8810#**
- Enable recall/flash hook functions (default) ***8811#**

TAPI voice dial compatibility

This feature allow the use of contact management, diallers and other software that use standard AT commands for dialling calls.

- Disable TAPI voice dial compatibility / set ETSI GSM mode (default) ***8820#**
- Enable TAPI voice dial compatibility ***8821#**

Line reverse signalling on outgoing call connection

Line reverse signalling may be used by PBX and other equipment to establish if an outgoing call has been connected. However some equipment may be confused by this signal, so this option is provided.

- Disable reverse signalling ***8830#**
- Enable reverse signalling (default) ***8831#**

Automatic switch off when charger plug is disconnected

When the DC plug is removed from the terminal's power socket, it will log off from the network (if connected) then switch off. This is the equivalent of pressing the red push button to turn off the unit.

- Disable Automatic switch off ***8840#**
- Enable Automatic switch off (default) ***8841#**

SMS remote status

It is possible to interrogate the status of the terminal by sending it an SMS (text message). The status will be returned to the phone that sent the message.

- Disable SMS remote status (default) ***8850#**
- Enable SMS remote status ***8851#**

The default setting is not to accept the remote status as it would conflict with applications that may want to use the terminal's SMS capability via the USB, for example an SMS server application.

When the remote status is enabled, the terminal selects the SIM memory for SMS and reads and deletes ALL incoming SMS. When it encounters an SMS beginning with '1234st' it will reply with the status:

1. *Signal level.*
2. *Charger power status.*
3. *If the charger power had been lost.*
4. *Battery voltage.*
5. *Temperature (reset after reading)*
6. *Number of missed calls.*
7. *IMEI*
8. *Firmware revision.*

Example SMS sent to the phone that requested the status:

Signal: -89dBm
Charger: on
Bat: 4.191 Volts
Temperature -
Now: 20
Min: 18
Max: 26
IMEI 353857016948321
Firmware: 2.6

Note in the above example, there had been no missed calls and the power had not failed at any time before the last status command, reset or turning on.

When the charger power is supplied, the battery level will stabilise between 4.1V and 4.2V. At other times the voltage may be as low as 3.6V, below this level the unit will turn itself off.

Compatibility mode

When compatibility mode is selected, the terminal will start operating as soon as charge power is applied to the unit and there is sufficient battery power. When charge power is removed, the unit will disconnect from the network and shut down. Setting *8841# has no effect in this mode. The centre green LED is permanently lit when the terminal is ready to make or receive calls.

- Disable Compatibility mode (default) ***8860#**
- Enable Compatibility mode ***8861#**

Restore factory settings [888]

Restore the following basic settings to their default values: 80, 81, 82, 83, 84, 880 and 881.

Other configuration settings remain unaltered. ***888#**

Advanced configuration codes

The advanced configuration codes may be entered using the telephone handset and also, when using a USB data connection, by using the dialling sequence “ATD” followed by the appropriate configuration code. When using the data connection (see page 8), it is additionally possible to interrogate the status of certain network settings, using the ***#** command prefix.

Call forwarding

Call forwarding is a network service which allows incoming calls to be diverted to an alternative number (such as a voicemail box) when certain criteria are met. In concert with your service provider, the terminal allows you to control various aspects of the call forwarding service. The various forwarding criteria are not mutually exclusive and can be used in combination to divert different types of calls to separate numbers. Commands are composed as follows:

[ACTION] criteria:

Forward unconditionally	21
Forward when busy	67
Forward when no reply	61
Forward when signal lost	62
Forward all calls	002
Forward all conditional types	004

<PHONE NUMBER>
to which calls that
meet the criteria
should be forwarded

Command
suffix

*** [ACTION] * <PHONE NUMBER> * <SERVICE> #**

Command prefixes:

Activate	*
Register and activate	**
Deactivate	#
Unregister and deactivate	##
Check status (interrogate) ¹	*#

¹ Interrogation is only possible via a data connection.

<SERVICE> types:

Voice only	11	Data circuit sync.	24
Fax only	13	PAD	27
SMS only	16	Packet	26
SMS+FAX	12	Data circuit async+PAD	21
Voice+FAX	19	Data circuit sync.+packet	22
Voice+SMS+FAX	10	Data circuit asyn.+sync.+PAD	20
Data circuit async.	25	All services	(omit code)

The *service type* allows you to optionally specify one or more particular types of incoming call to forward.

Call forwarding examples

- To register a new number and activate call forwarding when busy (to the phone number 01234 567890): ****67*01234567890*#**
- To deactivate call forwarding when busy: **#67***
- To reactivate call forwarding when busy to 01234 567890 again: ***67***

Call barring

Call barring is a network service which allows incoming and/or outgoing calls that meet certain criteria to be barred from being received or made. In concert with your service provider, the terminal allows you to control various aspects of the call barring service. The various barring criteria are not mutually exclusive and can be used in combination to produce a tighter set of barring regulations. Commands are composed as follows:

[ACTION] criteria:

Bar all outgoing calls	33
Bar all outgoing international calls	331
Bar all outgoing international calls except to home country	332
Bar all incoming calls	35
Bar all incoming calls outside of home country	351

Note: The PASSWORD is initially configured by the network service provider and is typically 0000 or 1111. This can be changed - see 'Security features' on page 27

***[ACTION]* [PASSWORD]* <SERVICE> #**

Command
suffix

Command prefixes:

Activate	*
Deactivate	#
Check status (interrogate) ¹	*#

¹ Interrogation is only possible via a data connection.

<SERVICE> types:

Voice only	11	Data circuit sync.	24
Fax only	13	PAD	27
SMS only	16	Packet	26
SMS+FAX	12	Data circuit async+PAD	21
Voice+FAX	19	Data circuit sync.+packet	22
Voice+SMS+FAX	10	Data circuit asyn.+sync.+PAD	20
Data circuit async.	25	All services	<i>(omit code)</i>

The *service type* allows you to optionally specify the services to be barred.

Deactivating collective barring settings

For all of the [ACTION] criteria shown above, it is possible to deactivate them individually using the # command type and their respective criteria codes. However, it is also possible to deactivate the following three barring groups collectively:

- Deactivate all barring **#330*[PASSWORD]*<SERVICE>#**
- Deactivate all outgoing barring **#333*[PASSWORD]*<SERVICE>#**
- Deactivate all incoming barring **#353*[PASSWORD]*<SERVICE>#**

Call barring examples

- To bar all international voice calls (where the password is 0000):
#331*0000*11#
- To deactivate all call barring (where the password is 1111):
#330*1111#

Call waiting

Call waiting is a network service that, when enabled, signals an incoming call when a call is already in progress and additionally allows the first call to be held while the second is answered. In concert with your service provider, the terminal allows you to control various aspects of the call waiting service. Commands are composed as follows:

***43* <SERVICE> #**

Command
suffix

Command prefixes:

Activate	*
Deactivate	#
Check status (interrogate) ¹	*#

¹ Interrogation is only possible via a data connection.

<SERVICE> types:

Voice only	11	Data circuit sync.	24
Fax only	13	PAD	27
SMS only	16	Packet	26
SMS+FAX	12	Data circuit async+PAD	21
Voice+FAX	19	Data circuit sync.+packet	22
Voice+SMS+FAX	10	Data circuit asyn.+sync.+PAD	20
Data circuit async.	25	All services	(omit code)

The *service type* allows you to optionally specify one or more particular types of incoming call which will be permitted to interrupt an existing call.

Call waiting examples

- To activate call waiting for all types of call: ***43#**
- To deactivate call waiting for all types of call: **#43#**

Security features

These commands relate to the security access features of the SIM card and network services.

- Unlock PIN1 ***8*[PIN1]#**
- Disable PIN1 lock¹ ***870*[PIN1]#**
- Enable PIN1 lock ***871*[PIN1]#**
- Change PIN1 ****04[old PIN]*[new PIN]*[new PIN]#**
- Change PIN2 ****042*[old PIN2]*[new PIN2]*[new PIN2]#**
- Unblock PIN1² ****05*[PUK]*[new PIN]*[new PIN]#**
- Unblock PIN2² ****052*[PUK]*[newPIN]*[newPIN]#**
- Unlock “PS” lock³ **#0003[MASTER PHONE CODE]#**
- Change call barring password⁴ ***03*330*[old PW]*[new PW]*[new PW]#**

Notes:

¹ Some SIM cards will not allow you to disable PIN1 protection.

² The PUK (Personal UnblockKey code) is provided by the service provider.

³ The PS (Phone to SIM) lock is an optional feature which ensures that the T350 terminal may only be used with a single SIM card. The Master Phone Code is issued by Burnside Telecom once the IMEI number (printed on the underside of the terminal) is declared. Please contact Burnside Telecom for more details about this optional feature.

⁴ Confirm the old call barring password with your network service provider.

Phone number presentation

These commands relate to the use of the Caller Line Identity (CLI) or Caller ID feature supported by the terminal.

- Use network CLI configuration (default) ***801#**
- Force sending CLI for all calls ***802#**
- Force withholding CLI for all calls ***803#**
- Make a single call and send CLI ***31#[phone number]**
- Make a single call and suppress CLI **#31#[phone number]**

The following commands need to be sent via a USB computer link in order to receive a valid response code.

- Check CLI presentation state ****30#** response: +CLIP: 0,n
- Check CLI sending state in network ****31#** response: +CLIR: 0,n
- Check presentation state of call ****76#** response: +COLP: 0,n
- Check presentation state of call ****77#** response: +COLR: 0,n

where *n* is 4 for active and 1 for inactive

Further information

Troubleshooting

If the amber light is indicating a fault, this may be caused by the following:

- **There is no SIM installed.**

Remedy: Turn off the unit and install a SIM. Then turn the unit back on.

- **There is no battery installed and/or connected.**

Remedy: Remove the power, install and connect the battery. Restore power.

- **The unit has overheated.**

Remedy: Locate the terminal in a cooler location. In particular keep out of direct sunlight.

- **Low signal indication or continuous searching indication (see page 14).**

Remedy, either locate the terminal in a more suitable position to achieve a stronger signal or use an antenna connected via a cable that has gain or is located in a more suitable location.

Important safety information

Battery

Do not use any other battery other than the one supplied with your terminal.

Power supply

Do not use any other power supply other than the one supplied with your terminal.
Failure to use either the supplied battery or charger can damage the terminal and will invalidate the warranty.

Operating environment

Make sure that no special regulations are in force that impose restrictions on the use of mobiles. Restrictions to mobiles would also apply to the terminal.

Electronic devices

Most modern electronic equipment is shielded from radio frequency (RF) signals. However, certain electronic equipment may not be shielded against the RF signals from your terminal.

Pacemakers

Pacemaker manufacturers recommend that a minimum separation of 20 cm (6 inches) be maintained between a hand-held wireless phone and a pacemaker. The same restriction should apply to the antenna of the terminal. If you have any reason to suspect that interference is taking place, switch off the terminal immediately.

Hearing aids

Some digital wireless phones may interfere with some hearing aids. In the event of such interference, you may want to consult your service provider.

Other medical devices

Operation of any radio transmitting equipment, including cellular phones, may interfere with the functionality of inadequately protected medical devices. Consult a physician or the manufacturer of the medical device to determine if they are adequately shielded from external RF energy or if you have any questions.

Switch off your terminal in health care facilities when any regulations posted in these areas instruct you to do so.

Hospitals or health care facilities may be using equipment that could be sensitive to external RF energy.

Vehicles

RF signals may affect improperly installed or inadequately shielded electronic systems in motor vehicles (e.g. electronic fuel injection systems, electronic anti-skid (anti-lock) braking systems, electronic speed control systems, air bag systems).

Check with the manufacturer or its representative regarding your vehicle. You should also consult the manufacturer of any equipment that has been added to your vehicle.

Potentially explosive atmospheres

Do not install the terminal or site the antenna in any area with a potentially explosive atmosphere and obey all signs and instructions.

Areas with a potentially explosive atmosphere are often but not always clearly marked. They include below deck on boats; chemical transfer or storage facilities; vehicles using liquefied petroleum gas (such as propane or butane); areas where the air contains chemicals or particles, such as grain, dust or metal powders.

Emergency calls

Important! This terminal, like any wireless phone, operates using radio signals, wireless and landline networks, as well as user-programmed functions, which cannot guarantee connection in all conditions.

Therefore, you should never rely solely upon any wireless device for essential communications (e.g. medical emergencies).

Remember, to make or receive any calls, your terminal must be switched on and in a service area with adequate cellular signal strength. Emergency calls may not be possible on all wireless phone networks or when certain network services and/or phone features are in use. Check with local cellular service providers.

Index

- A**
 - Alternate line
 - service selection 20
 - Antenna
 - connection 6
- B**
 - Battery
 - connection 5
- C**
 - Call barring
 - configuration 25
 - password change 27
 - Caller ID
 - configuration 27
 - control codes 19
 - type selection 20
 - Caller Line Identity.
 - See Caller ID
 - Call forwarding
 - configuration 24
 - Calls
 - emergency 15
 - making and receiving 15
 - Call waiting
 - configuration 26
 - in-call options 16
 - CLI. *See* Caller ID
 - Clock
 - setting 21
 - Conference calls
 - in-call options 17
 - Configuration codes
 - advanced 24
 - basic 19
 - entering 18
 - Cover
 - removal 4
- D**
 - Dial delay 19
- E**
 - Emergency calls 15
- F**
 - Factory
 - reset 23
 - Fax
 - connection 8
 - Flashing codes 14
- I**
 - In-call dialling 17
 - Indicators
 - status 14
 - when switching on 7
- P**
 - PBX
 - related settings 21
 - PIN code 16
 - configuration 27
 - entering 7
 - Positioning 5
 - Power
 - switch on/off 7
 - Power adapter
 - connection 6
 - Power loss 15
 - PUK code 16
- R**
 - Reset 23
 - Ring back test 15
 - Ringling style 20
- S**
 - Safety information 28
 - Signal strength 5
 - SIM card
 - installation 4
 - Supplied items 2
 - Switch on/off 7
- T**
 - Telephone
 - connection 6
 - Testing
 - ring back 15
 - Troubleshooting 28
- V**
 - Volume boost 20

Documentation by:



www.ctxd.com

T350/T390 mounting template

Use this template to position screw holes when wall mounting the terminal.

You are recommended to use 3mm x 30 pan-head screws.

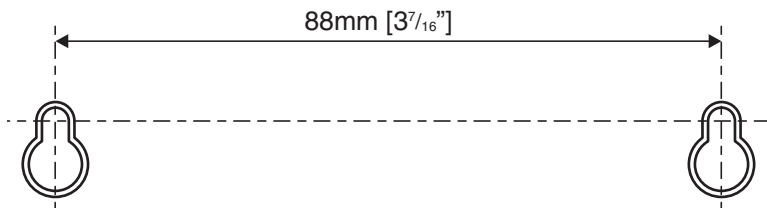

Burnside Telecom Limited

Burnside House, Isington, Alton
GU34 4PP, United Kingdom

Tel: +44 (0)8700 76276

Fax: +44 (0)1420 520029

Email: info@burnsidetelecom.com

